

PRELIMINARY ISSUE
THIS PLAN ISSUED FOR
ADVANCE INFORMATION ONLY

N.A.D 1983 FEET COORDINATES		
CHANNEL	NORTH	EAST
08	2156972.67	6020299.00
09	2157666.40	6019811.96
10	2156366.16	6023187.69
11	2157068.34	6022179.34
12	2156266.20	6024797.61
13	2156977.43	6023175.20
14	2156630.06	6025133.87
15	2157243.59	6024071.67
16	2157620.81	6025096.39
17	2157571.89	6024244.59
18	2156899.14	6024794.29
19	2159896.43	6023863.10
20	2159700.46	6024629.96

SHEET INDEX

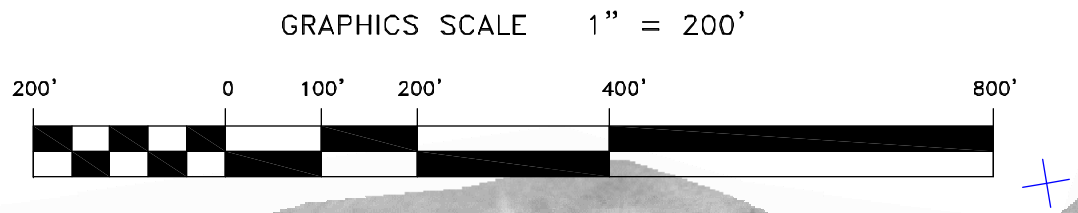
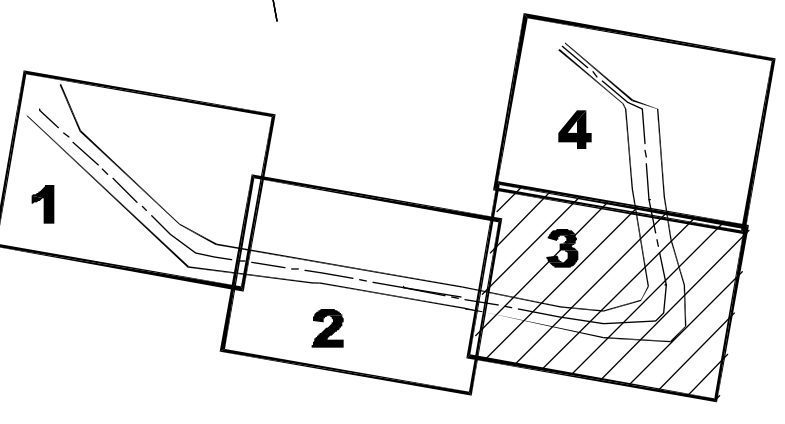

US Army Corps
of Engineers
San Francisco District
1455 Market Street
San Francisco, CA 94103

Mark	Description	Date	Appr.

DESIGNED BY:	DT	CHECKED BY:	DT	DRAWN BY:	DT
DATE:	12/14/2011	DATE:	12/14/2011	DATE:	12/14/2011
SHEET NO.:	3 OF 4	SHEET NO.:	3 OF 4	SHEET NO.:	3 OF 4
APPROVAL RECOMMENDED:			APPROVAL RECOMMENDED:		
CHIEF, Geomatics Section			CHIEF, Geomatics Section		
APPROVED:			APPROVED:		
TORREY A. DIGIRO			TORREY A. DIGIRO		
LT. COLONEL, C.E., DISTRICT ENGINEER			LT. COLONEL, C.E., DISTRICT ENGINEER		

ALAMEDA COUNTY CALIFORNIA
RICHMOND INNER HARBOR
 POSTDRAGE SURVEY
 17-19, 21, 28, 31 OCTOBER 2011
 21 & 29 NOVEMBER 2011
 7-8 DECEMBER 2011

Sheet reference number
C3