

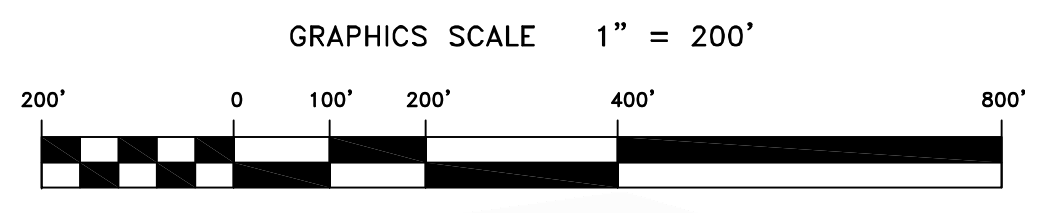

PRELIMINARY ISSUE
 THIS PLAN ISSUED FOR
 ADVANCE INFORMATION ONLY

SHEET INDEX

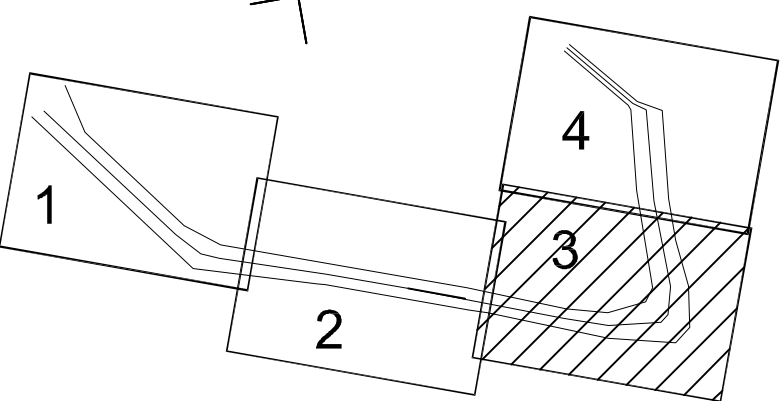

Mark	Description	Date	Appr.

DESIGNED BY:	CHECKED BY:	PDT	DRAWING NO.		
			SHEET NO.	OF	TOTAL
Hydro Survey Team Leader	PDT	PDT	3	OF	4
DATE:	DATE:	DATE:	8/5/2014		9 2
APPROVAL RECOMMENDED:	APPROVED:	PREPARED UNDER THE DIRECTION OF:	JOHN K. BAKER		
Chief, Hydro Survey Section	Chief, Construction Branch	LT. COLONEL, C.E., DISTRICT ENGINEER			

CALIFORNIA
 ALAMEDA COUNTY
**RICHMOND INNER HARBOR
 CONDITION SURVEY**
 28-29 MAY 2014

Sheet
 reference
 number
C3