

MATCHLINE - SHEET 1

MATCHLINE - SHEET 3

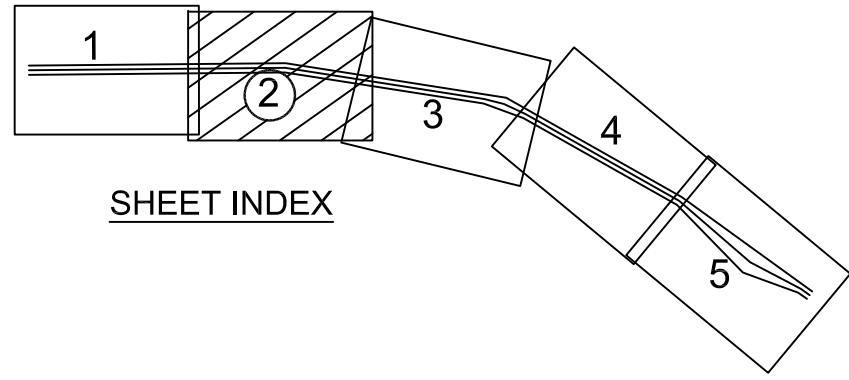

PRELIMINARY ISSUE
 THIS PLAN ISSUED FOR
 ADVANCE INFORMATION ONLY

Mark	Description	Date	Appr.

SUBMITTED: PDT Hydro Survey Team Leader APPROVAL RECOMMENDED: STEPHEN P. KILMON, P.S.M. Chief, Geomatics Section APPROVED:	DESIGNED BY: DATE: 05/28/2010	CHECKED BY:	DRAWN BY:
PREPARED UNDER THE DIRECTION OF LAURENCE M. FARRELL LT. COLONEL, C.E., DISTRICT ENGINEER	SHEET NO. 2 OF 5	PLOT 3	PLOT XXX

CALIFORNIA
 SAN PABLO BAY
**PINOLE SHOALS
 PREDREDGE SURVEY**
 24, 27-28 MAY 2010

Sheet reference number
S2

US Army Corps
 of Engineers
 San Francisco District
 1455 Market Street
 San Francisco, CA 94103