

US Army Corps
of Engineers
San Francisco District
1455 Market Street
San Francisco, CA 94103

PRELIMINARY ISSUE
THIS PLAN ISSUED FOR
ADVANCE INFORMATION ONLY

Mark	Description	Date	Appr.

CHECKED BY:	DRAWN BY:
PPC	PPC
TWV	TWV
DRAWING NO.	DRAWING NO.
3	2
03/20/2009	2 OF 5
PREPARED UNDER THE DIRECTION OF	PREPARED UNDER THE DIRECTION OF
LAURENCE M. FARRELL	LAURENCE M. FARRELL
LT. COLONEL, C.E.	DISTRICT ENGINEER

SAN PABLO BAY
CALIFORNIA
PINOLE SHOALS
CONDITION SURVEY
3, 4 & 5 MARCH 2009

Sheet
reference
number
C2

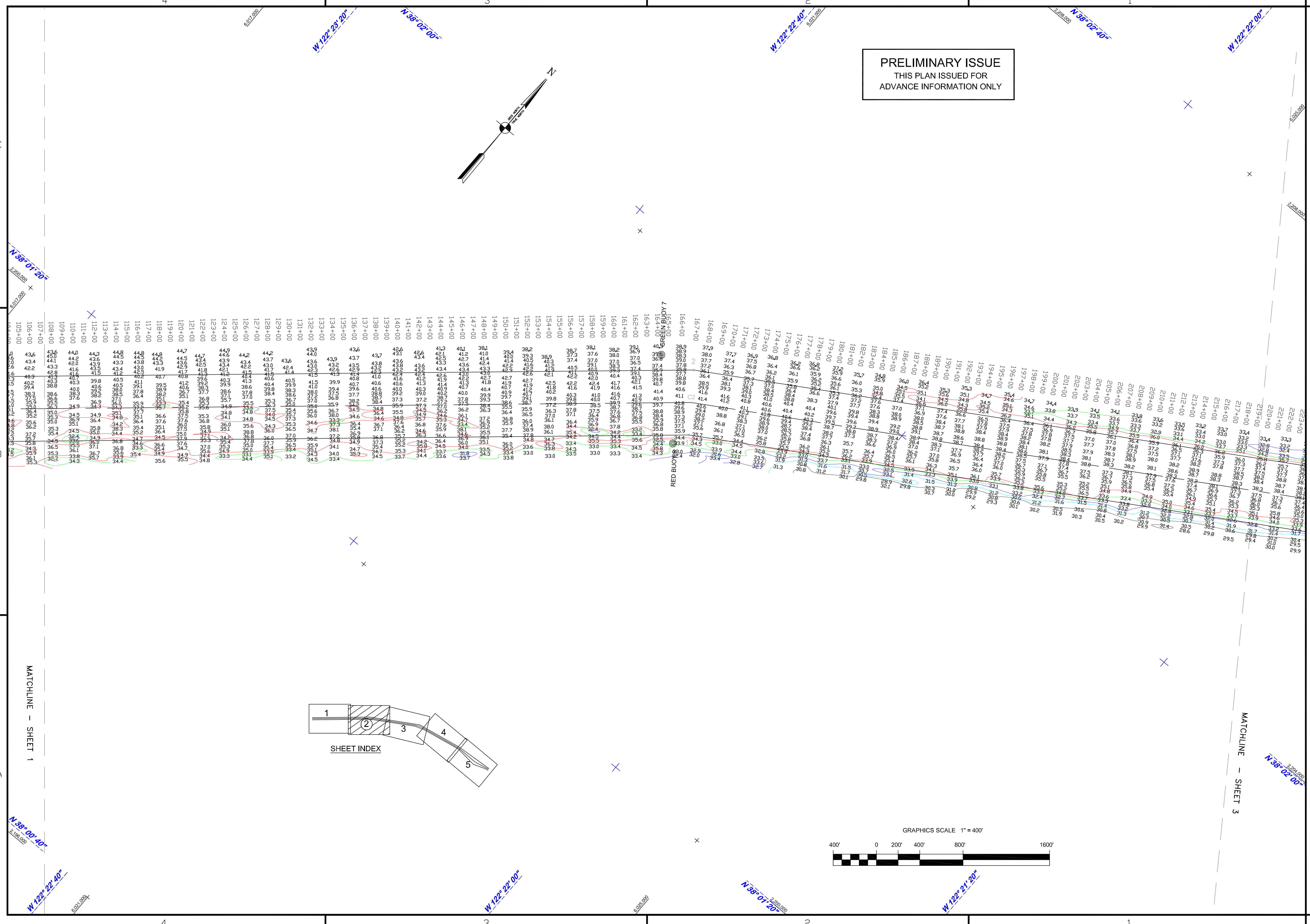
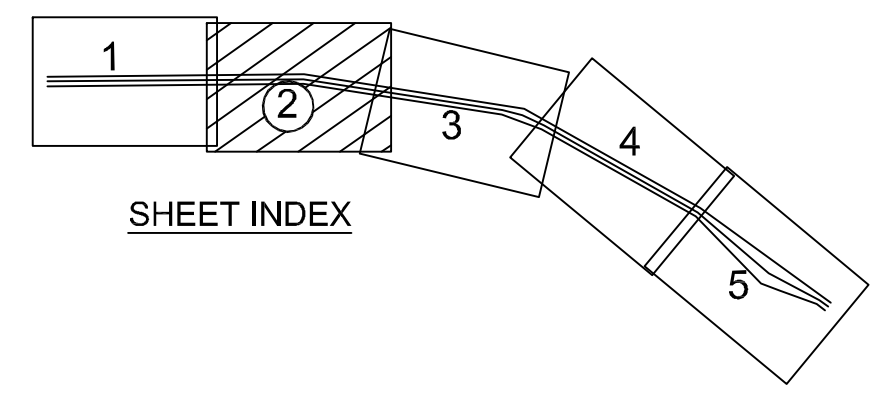
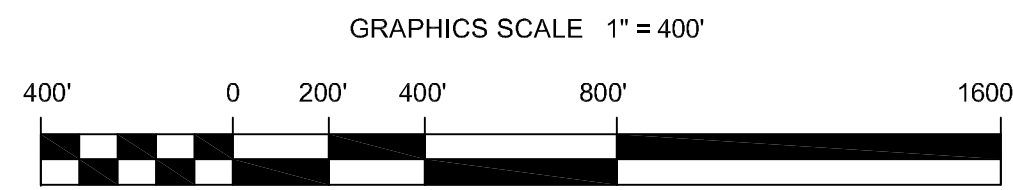
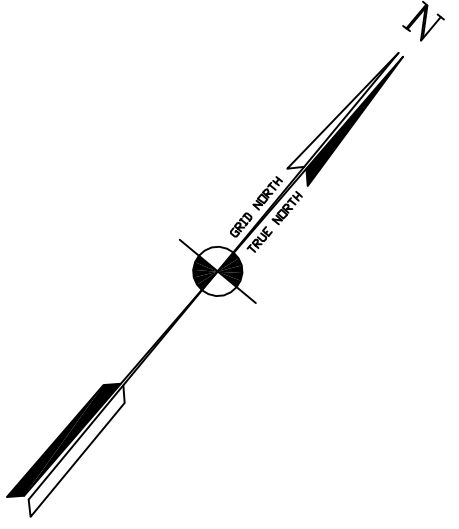

MATCHLINE - SHEET 1

MATCHLINE - SHEET 3

N 38° 00' 40"

N 38° 02' 00"

4

3

2

1

4

3

2

1