

PRELIMINARY ISSUE
THIS PLAN ISSUED FOR
ADVANCE INFORMATION ONLY

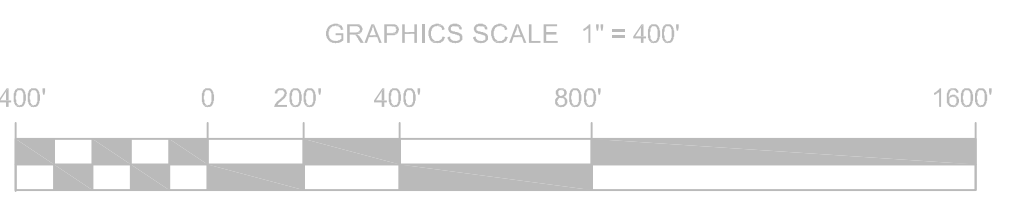
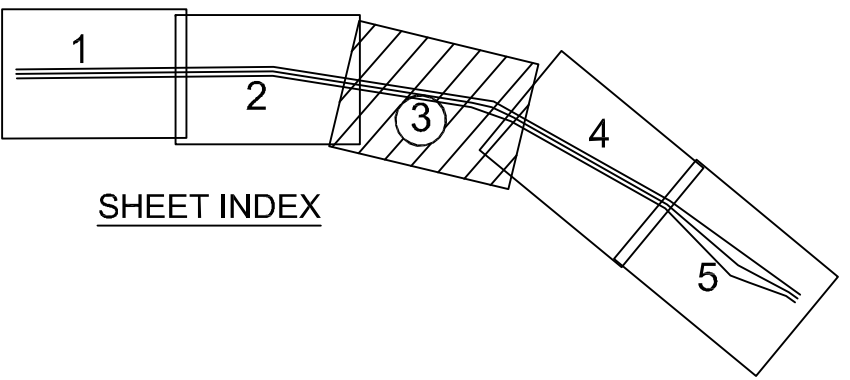
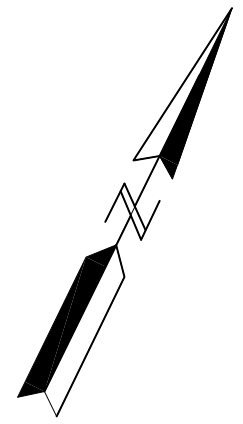

US Army Corps
of Engineers
San Francisco District
1455 Market Street
San Francisco, CA 94103

Mark	Description	Date	Appr.

SUBMITTED:	PDT	DESIGNED BY:	DRAWN BY:
	Hydro Survey Team Leader	PDT	PDT
APPROVAL RECOMMENDED:	STEPHEN P. KILMON, P.S.M.	DATE:	07/14/2010
	Chief, Geomatics Section	SHEET NO.	3
	APPROVED:	PREPARED UNDER THE DIRECTION OF	LAURENCE M. FARRELL
	Chief, Construction Branch		LT. COLONEL, C.E., DISTRICT ENGINEER

CALIFORNIA
SAN PABLO BAY
PINOLE SHOALS
POSTDREDGE SURVEY
8-10 JULY 2010

Sheet reference
number
G3