

PRELIMINARY ISSUE
THIS PLAN ISSUED FOR
ADVANCE INFORMATION ONLY

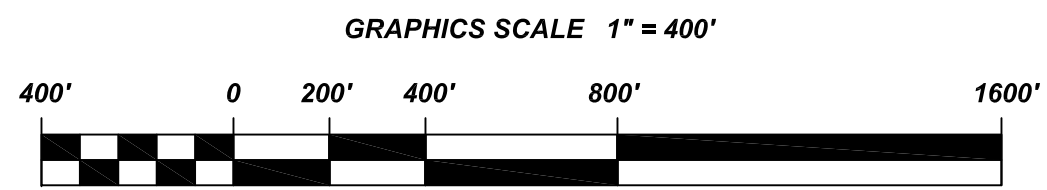
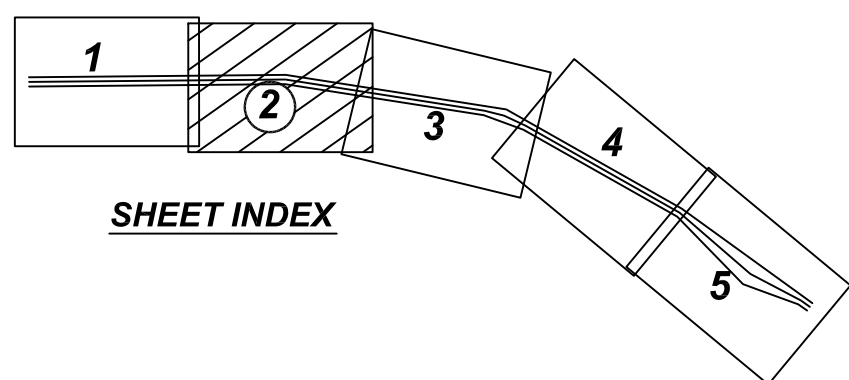
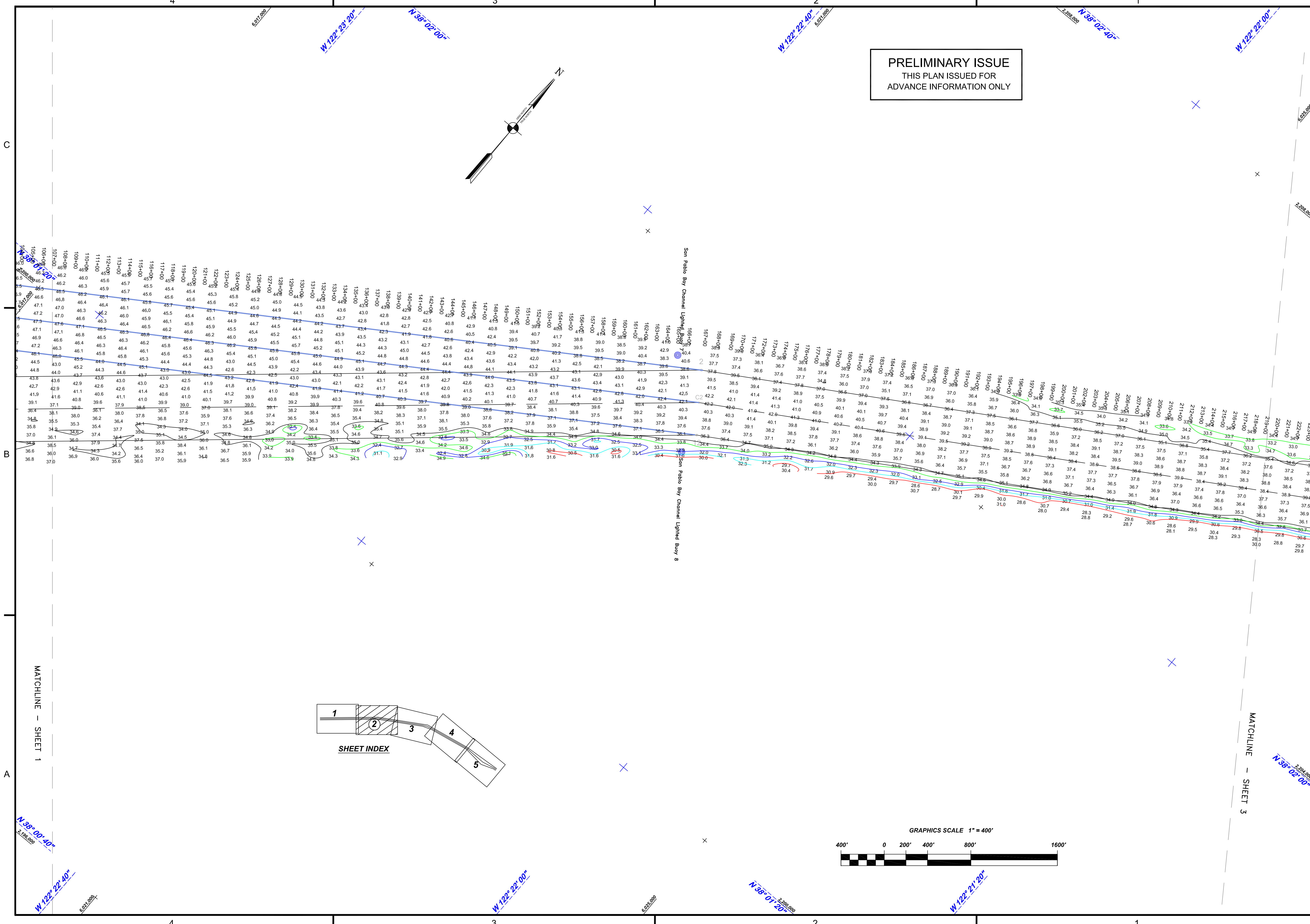

Mark	Description	Date	Appr.

DESIGNED BY:	DRAWN BY:	CHECKED BY:	PDT
DATE:	2/21/2013	DATE:	2/21/2013
APPROVAL RECOMMENDED:	CHIEF, HYDRO SURVEY SECTION	APPROVED:	JOHN K. BAKER
APPROVED:	CHIEF, CONSTRUCTION BRANCH	APPROVED:	LT. COLONEL, C.E., DISTRICT ENGINEER

CALIFORNIA
SAN PABLO BAY
PINOLE SHOALS
CONDITION SURVEY
06 FEBRUARY 2013

Sheet reference number
C2