

PRELIMINARY ISSUE
THIS PLAN ISSUED FOR
ADVANCE INFORMATION ONLY

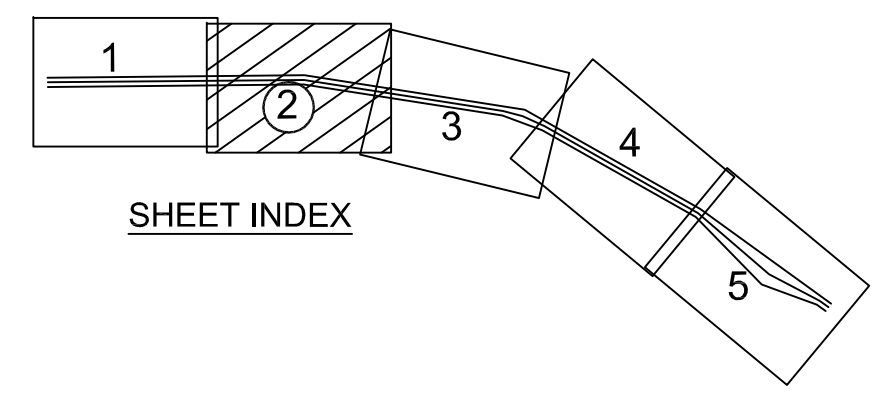
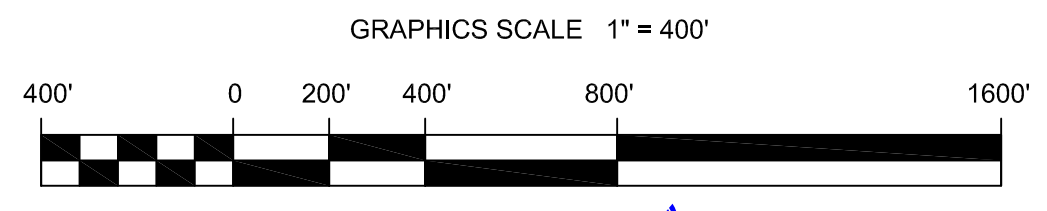
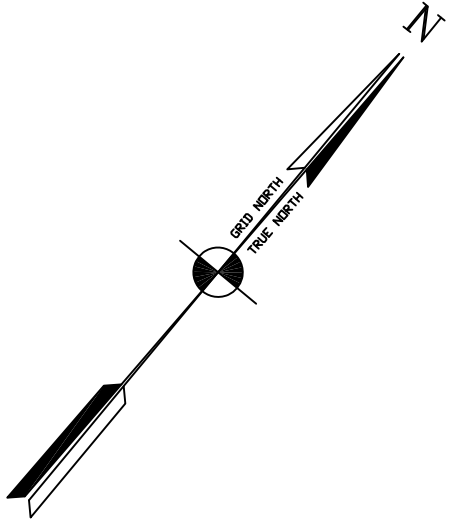

US Army Corps
of Engineers
San Francisco District
1455 Market Street
San Francisco, CA 94103

Mark	Description	Date	Appr.

DESIGNED BY:	MC	CHECKED BY:	TVW	EWC
APPROVAL RECOMMENDED:	Hydro Survey Team Leader	DATE:	11/24/2008	SHEET NO.
APPROVED:	Chief, Technical Support Section		2	5
	Chief, Construction Branch		3	2
			2	226
			DRAWING NO.	
			PREPARED UNDER THE DIRECTION OF	
			LAURENCE M. FARRELL	
			LT. COLONEL, C.E., DISTRICT ENGINEER	

CALIFORNIA
SAN PABLO BAY
PINOLE SHOALS
PREDECESSOR SURVEY
7-13 NOVEMBER 2008

Sheet reference
number
C2

MATCHLINE - SHEET 1

MATCHLINE - SHEET 3