

US Army Corps
of Engineers
San Francisco District
1455 Market Street
San Francisco, CA 94103

Mark	Description	Date	Appr.

DESIGNED BY:	MC	SUBMITTED:	MC
DATE:	4/21/2008	APPROVAL RECOMMENDED:	Hydro Survey Team Leader
DESIGNED BY:	TW	APPROVED:	Chief, Technical Support Section
CHECKED BY:	EWC	APPROVED:	Chief, Construction Branch
DRAWN BY:	EWC	PREPARED UNDER THE DIRECTION OF CRAIG W. KILEY LT. COLONEL, C.E., DISTRICT ENGINEER	
DRAWING NO.	214 2 5	CALIFORNIA PINOLE SHOALS CONDITION SURVEY 24, 26-28, 31 MARCH AND 01 & 16 APRIL 2008	

SAN PABLO BAY

Sheet reference number

C4

PRELIMINARY ISSUE
THIS PLAN ISSUED FOR
ADVANCE INFORMATION ONLY

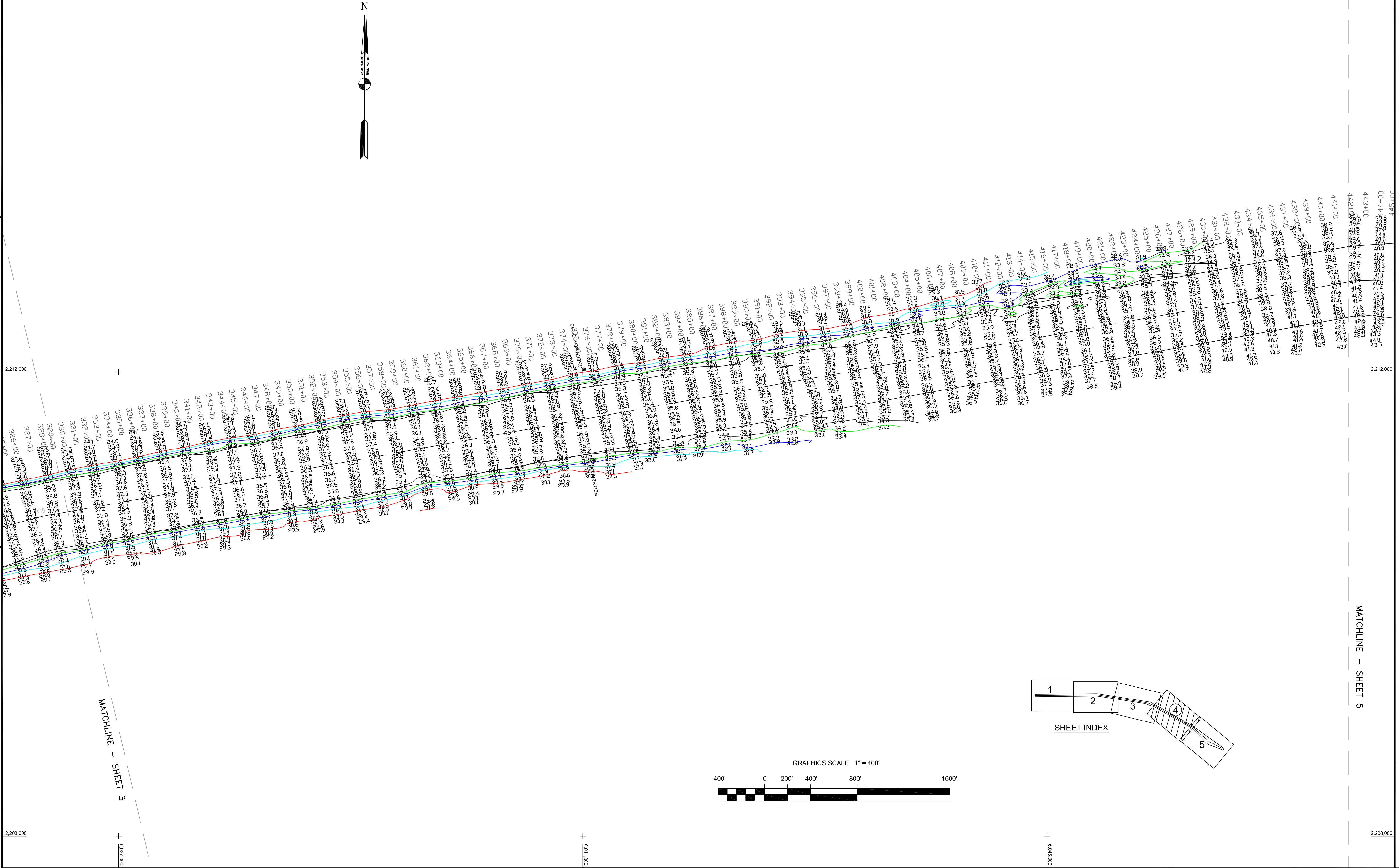
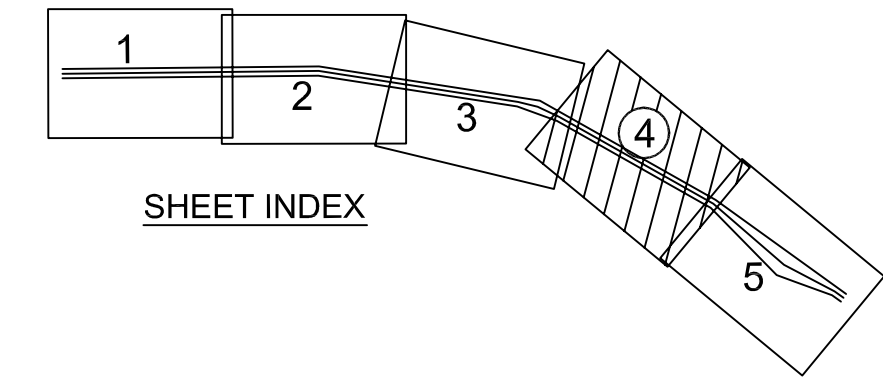
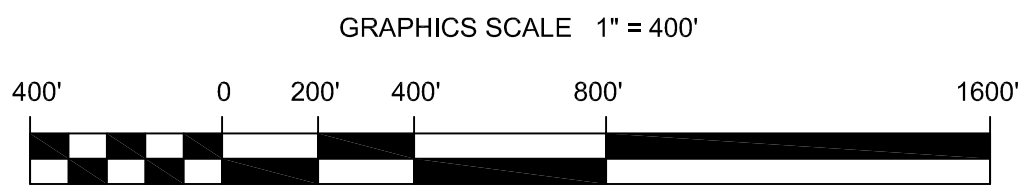

2,216,000
2,212,000
2,208,000

0.004,000
0.002,000
0.000,000

2,216,000
2,212,000
2,208,000

0.004,000
0.002,000
0.000,000

MATCHLINE - SHEET 5