

Mark	Description	Date	Appr.

DESIGNED BY:	MC	CHECKED BY:	TVW	EWC
DATE:	4/21/2008	SHEET NO.	2	DRAWING NO.
APPROVAL RECOMMENDED:	Hydro Survey Team Leader	DATE:	4/21/2008	2
APPROVED:	Chief, Technical Support Section	PREPARED UNDER THE DIRECTION OF	CRAIG W. KILEY	214
	Chief, Construction Branch			

CALIFORNIA
 SAN PABLO BAY
 PINOLE SHOALS
 CONDITION SURVEY
 24, 26-28, 31 MARCH
 AND 01 & 16 APRIL 2008

Sheet reference number
 C2

PRELIMINARY ISSUE
 THIS PLAN ISSUED FOR
 ADVANCE INFORMATION ONLY

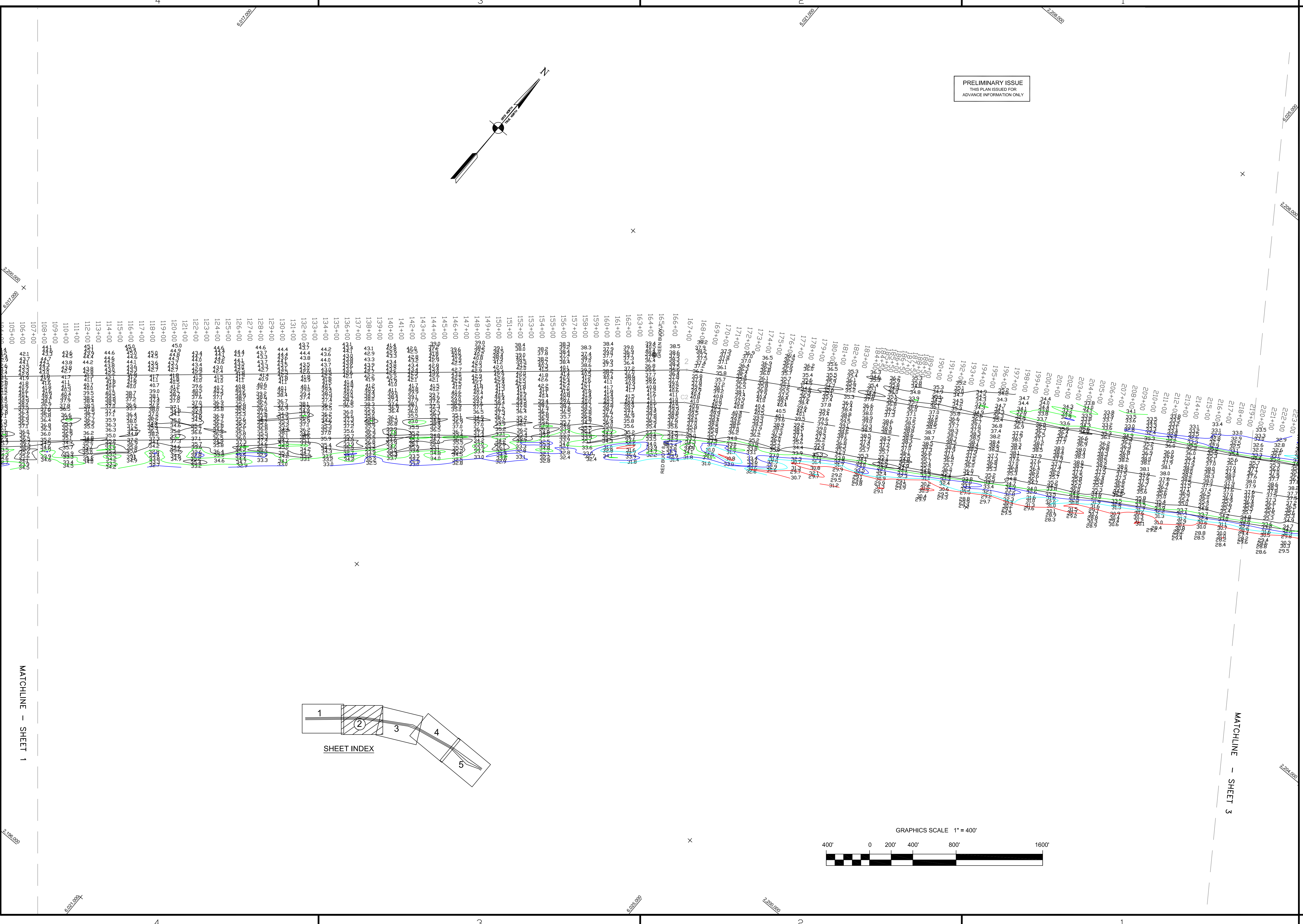
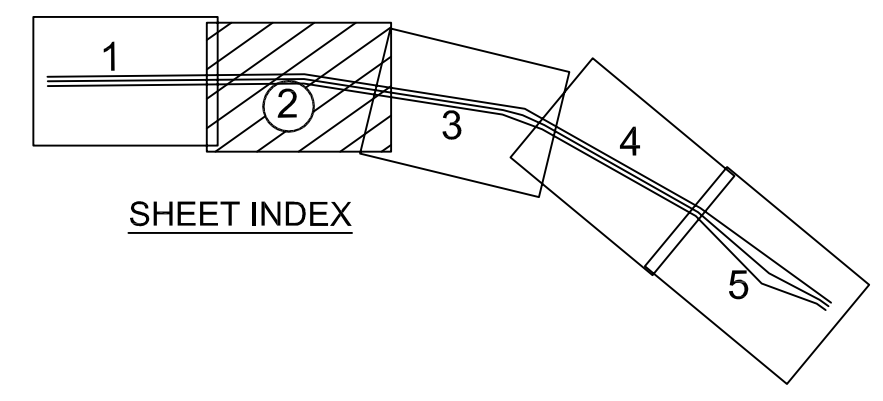
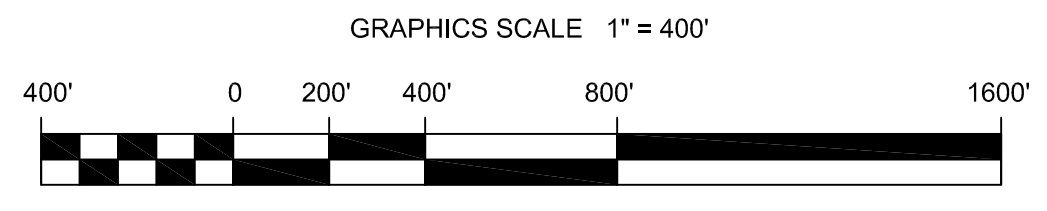
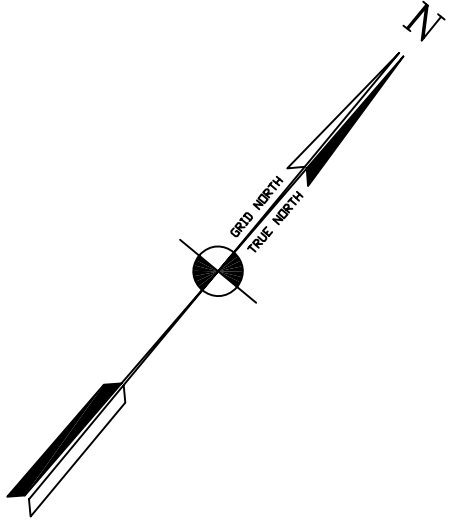

4 3 2 1

4 3 2 1

C

B

A

MATCHLINE - SHEET 1

MATCHLINE - SHEET 3