

PRELIMINARY ISSUE  
THIS PLAN ISSUED FOR  
ADVANCE INFORMATION ONLY

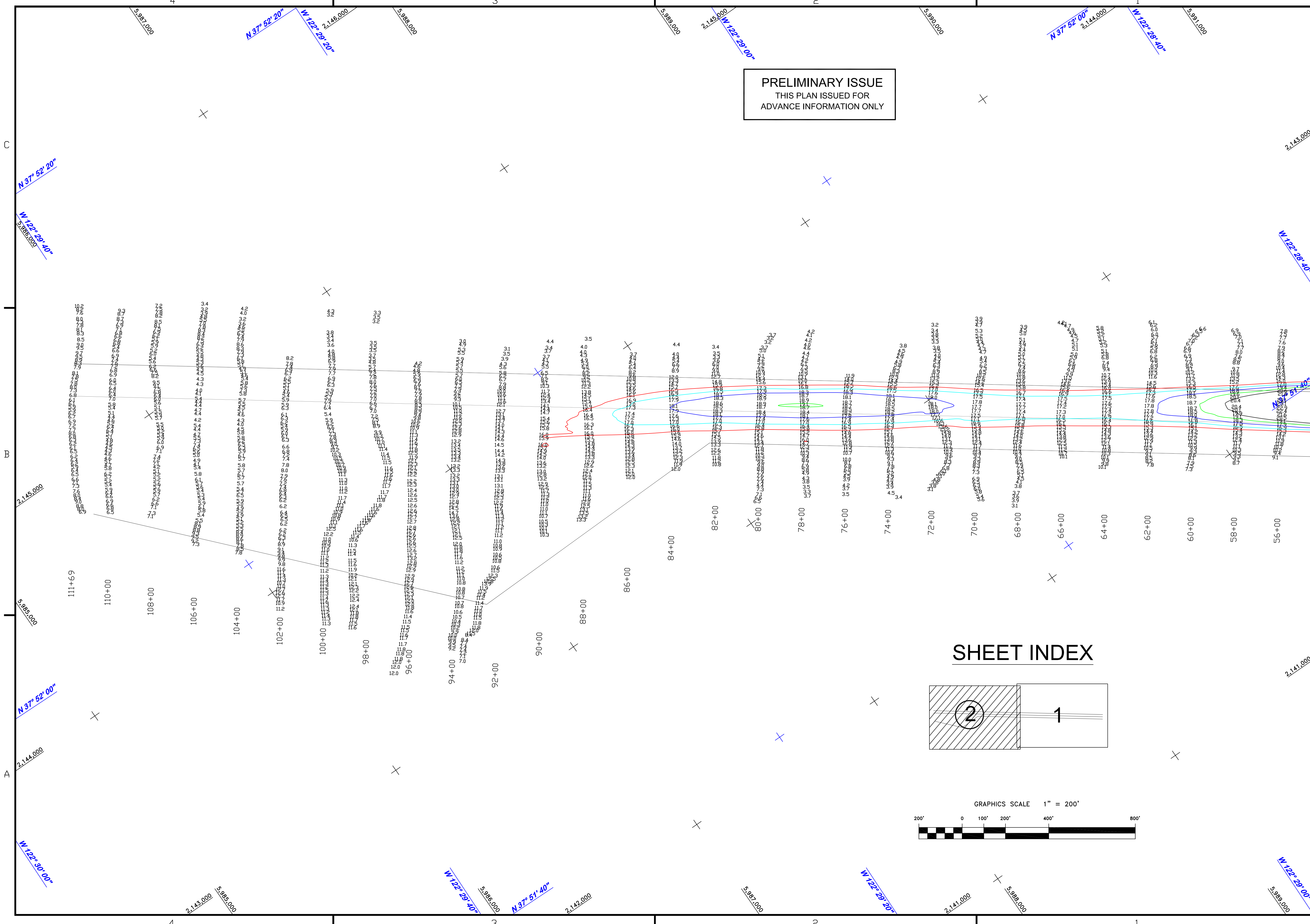

SHEET INDEX

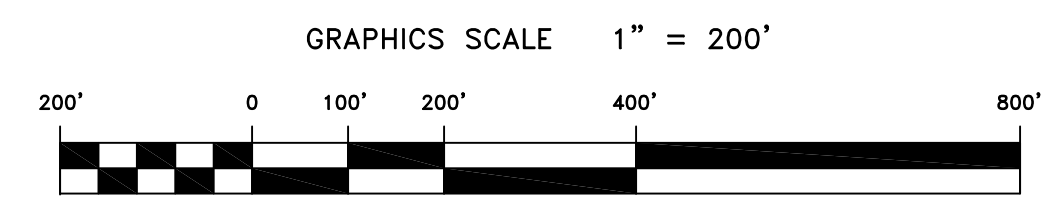
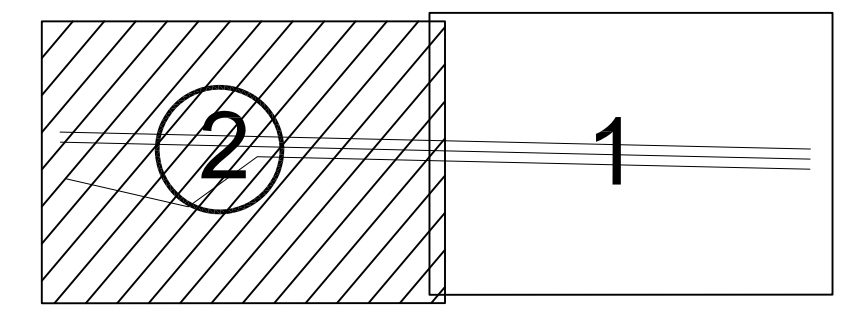

Mark	Description	Date	Appr.

SUBMITTED:		DESIGNED BY:		CHECKED BY:		DRAWN BY:	
PDT	Team Leader	PDT	Team Leader	PDT	Team Leader	PDT	Team Leader
APPROVAL RECOMMENDED:		DATE:		SHEET NO.		DRAWING NO.	
		12/18/2012		1 OF 3		133 2	
APPROVED:		PREPARED UNDER THE DIRECTION OF					
		JOHN K. BAKER					
		LT. COLONEL, C.E., DISTRICT ENGINEER					

MARIN COUNTY CALIFORNIA  
MARINSHIP CHANNEL  
(RICHARDSON BAY)  
CONDITION SURVEY  
18 DECEMBER 2012

Sheet reference number  
C2