

N 2,159,212  
N 2,157,212  
N 2,156,212

N 2,159,212  
N 2,158,212  
N 2,157,212  
N 2,156,212

**PRELIMINARY ISSUE**  
THIS PLAN ISSUED FOR  
ADVANCE INFORMATION ONLY

**SHEET INDEX**

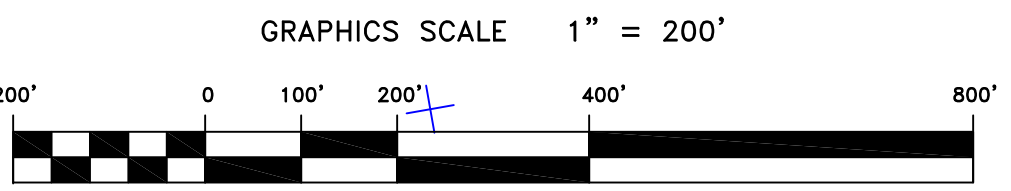
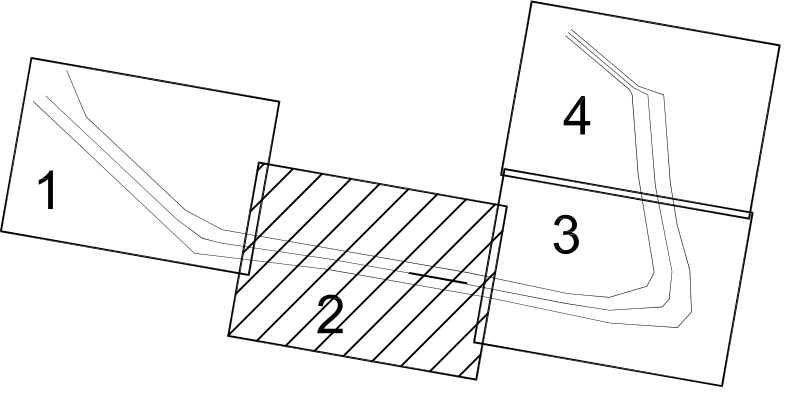

| Station | Depth (ft) | Other Data |
|---------|------------|------------|
| 62+00   | 22.9       | ...        |
| 63+00   | 22.9       | ...        |
| 64+00   | 22.9       | ...        |
| 65+00   | 22.9       | ...        |
| 66+00   | 22.9       | ...        |
| 67+00   | 22.9       | ...        |
| 68+00   | 22.9       | ...        |
| 69+00   | 22.9       | ...        |
| 70+00   | 22.9       | ...        |
| 71+00   | 22.9       | ...        |
| 72+00   | 22.9       | ...        |
| 73+00   | 22.9       | ...        |
| 74+00   | 22.9       | ...        |
| 75+00   | 22.9       | ...        |
| 76+00   | 22.9       | ...        |
| 77+00   | 22.9       | ...        |
| 78+00   | 22.9       | ...        |
| 79+00   | 22.9       | ...        |
| 80+00   | 22.9       | ...        |
| 81+00   | 22.9       | ...        |
| 82+00   | 22.9       | ...        |
| 83+00   | 22.9       | ...        |
| 84+00   | 22.9       | ...        |
| 85+00   | 22.9       | ...        |
| 86+00   | 22.9       | ...        |
| 87+00   | 22.9       | ...        |
| 88+00   | 22.9       | ...        |
| 89+00   | 22.9       | ...        |
| 90+00   | 22.9       | ...        |
| 91+00   | 22.9       | ...        |
| 92+00   | 22.9       | ...        |
| 93+00   | 22.9       | ...        |
| 94+00   | 22.9       | ...        |
| 95+00   | 22.9       | ...        |
| 96+00   | 22.9       | ...        |
| 97+00   | 22.9       | ...        |
| 98+00   | 22.9       | ...        |
| 99+00   | 22.9       | ...        |
| 100+00  | 22.9       | ...        |
| 101+00  | 22.9       | ...        |
| 102+00  | 22.9       | ...        |
| 103+00  | 22.9       | ...        |
| 104+00  | 22.9       | ...        |
| 105+00  | 22.9       | ...        |
| 106+00  | 22.9       | ...        |
| 107+00  | 22.9       | ...        |
| 108+00  | 22.9       | ...        |
| 109+00  | 22.9       | ...        |
| 110+00  | 22.9       | ...        |
| 111+00  | 22.9       | ...        |
| 112+00  | 22.9       | ...        |
| 113+00  | 22.9       | ...        |
| 114+00  | 22.9       | ...        |
| 115+00  | 22.9       | ...        |
| 116+00  | 22.9       | ...        |
| 117+00  | 22.9       | ...        |
| 118+00  | 22.9       | ...        |
| 119+00  | 22.9       | ...        |

**US Army Corps of Engineers**  
San Francisco District  
1455 Market Street  
San Francisco, CA 94103

---

| Mark | Description | Date | Appr. |
|------|-------------|------|-------|
|      |             |      |       |
|      |             |      |       |
|      |             |      |       |

---

|   |             |              |     |
|---|-------------|--------------|-----|
| DESIGNED BY:  | CHECKED BY: | DRAWN BY:    | PDT |
| DATE:   | SHEET NO.:  | DRAWING NO.: | PDT |
| 02/25/2013  | 2 OF 4      | 9            | 2   |
| PREPARED UNDER THE DIRECTION OF<br><b>JOHN K. BAKER</b><br>LT. COLONEL, C.E., DISTRICT ENGINEER |             |              |     |

---

|                       |           |                             |
|-----------------------|-----------|-----------------------------|
| SUBMITTED:            | PDT       | HYDRO SURVEY TEAM LEADER    |
| APPROVAL RECOMMENDED: | APPROVED: | CHIEF, HYDRO SURVEY SECTION |

---

ALAMEDA COUNTY CALIFORNIA  
**RICHMOND INNER HARBOR**  
POSTDRUDGE SURVEY  
11 JANUARY - 12 FEBRUARY 2013

---

Sheet reference number  
**C2**