

**LEGEND:**

<span style="color: black;">—</span>	-38'
<span style="color: green;">—</span>	-37'
<span style="color: blue;">—</span>	-36'
<span style="color: cyan;">—</span>	-35'
<span style="color: red;">—</span>	-34'

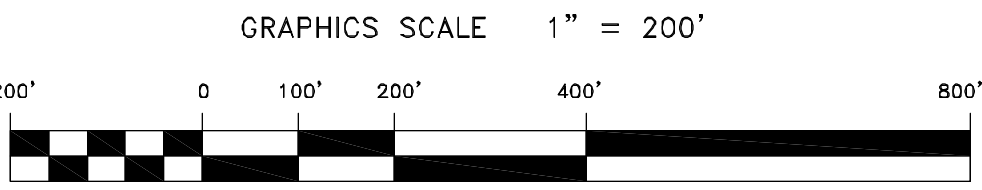
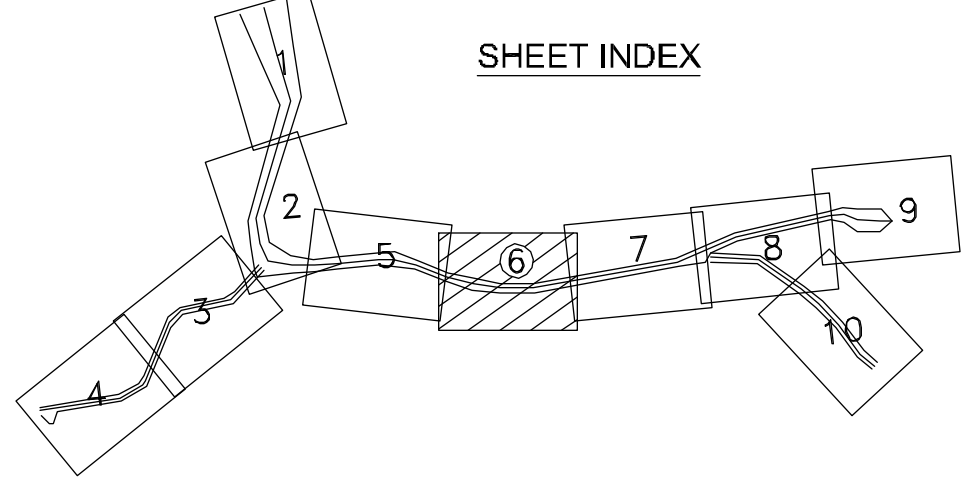

**PRELIMINARY ISSUE**  
THIS PLAN ISSUED FOR  
ADVANCE INFORMATION ONLY

US Army Corps  
of Engineers  
San Francisco District  
455 Market Street  
San Francisco, CA 94103

Mark	Description	Date	Appr.

<b>SUBMITTED:</b>	<b>PDT</b> Hiro Survey Team Leader	<b>DESIGNED BY:</b>	<b>PD</b> John K. Baker
<b>APPROVAL RECOMMENDED:</b>	<b>DATE:</b> 3/7/2013	<b>CHECKED BY:</b>	<b>PDT</b> John K. Baker
<b>APPROVED:</b>	<b>SHEET NO.:</b> 6 OF 10	<b>DRAWING NO.:</b> X XXX	<b>DATE:</b> 3/7/2013

PREPARED UNDER THE DIRECTION OF  
**JOHN K. BAKER**  
LT. COLONEL, C.E., DISTRICT ENGINEER

HUMBOLDT COUNTY CALIFORNIA  
**HUMBOLDT BAY  
NORTH BAY CHANNEL  
CONDITION SURVEY**  
23-28 FEBRUARY 2013

Sheet  
reference  
number  
**C6**